



Allied Design Studio 2023

The Allied Design Studio is a course added through curriculum optimization to reinforce design knowledge among students. It was conducted in Winter 2022 for Semester I & III and in Summer 2023 for Semester II & IV.

Semester I

Course objective

1. The students will be able to sketch using different mediums
2. The students will be able to sketch at various scales.
3. The students will develop an understanding of light, shade and shadow, textures and volumes.

Exercised devised:

1. Quick sketching with pencil
2. Blind contour drawing
3. Sketching postures with charcoal
4. Sketching surrounding with ink and kitta
5. Drawing what you see with ink

Semester II

Course objective

1. The students will learn to identify the rules of visual composition and organization.
2. Students will learn to identify the rules of composition.
3. The students will be able to apply the basics of colour theory.

Exercise devised:

1. Deciphering rules of organization in architectural plans.
2. Deciphering rules of composition in surrounding.
3. Representing colour harmonies.
4. Preparing mood board.
5. Composition of a Designer's Colour Palette

Semester III

Course objective

1. To document the design process, understand material behavior and its aesthetic quality.
2. To generate 1:1 scale model of the studied material to design an artifact.



Exercise devised

1. The students will be able to make an assemblage with an understanding of overall composition and joinery among different materials.
2. The students will be able to carry out operations like cutting, drilling, bending, riveting, threading, screwing and sanding/ fitting with metal and wood, using hand-and power-tools at the workshop.
3. The students will explore possibilities of the different types of joinery for the same or different material.


Semester IV

Course objectives

1. The students will develop an understanding of community
2. The students will learn how to represent intangible aspects of design

Exercise devised

1. Study of a village in Ladakh to understand the cultural practices, livelihood, daily routines, etc.


Principal
Ideas
Institute of Design Education &
Architectural Studies, Nagpur



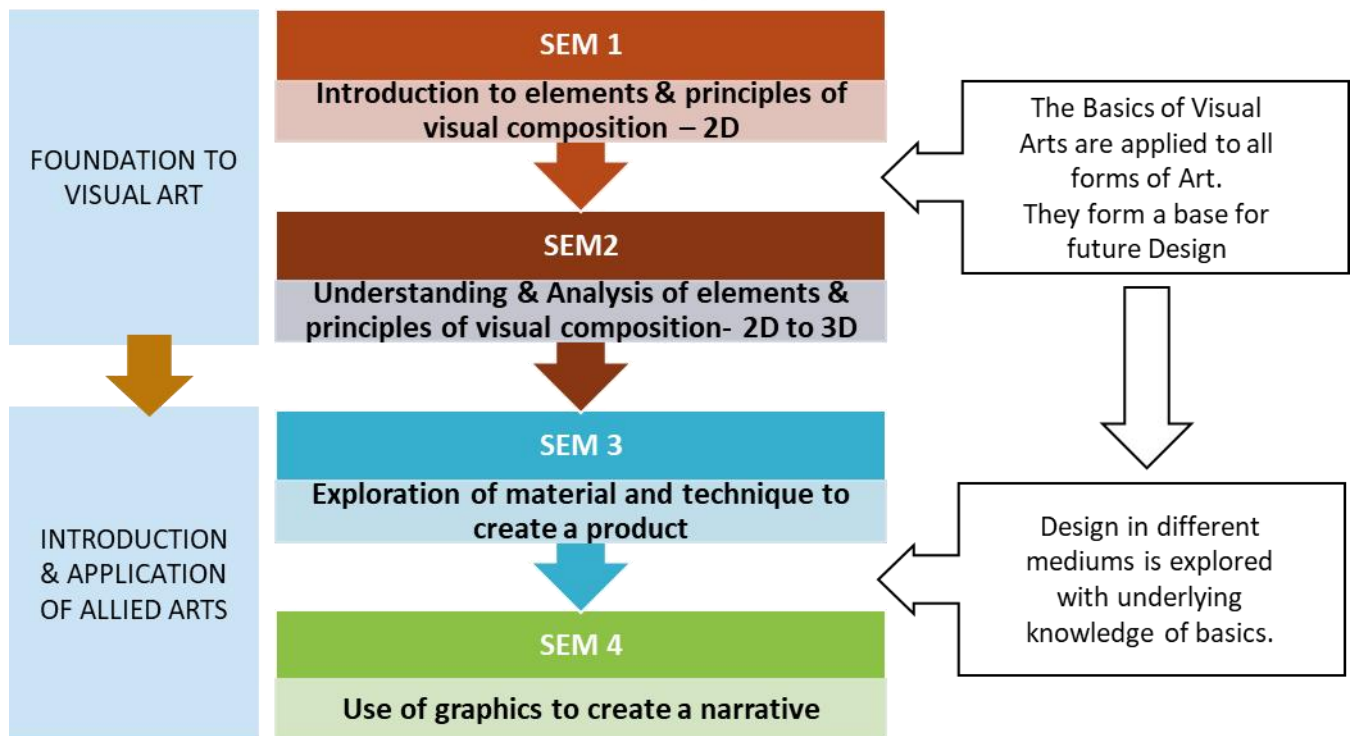
A. Allied Design Studio

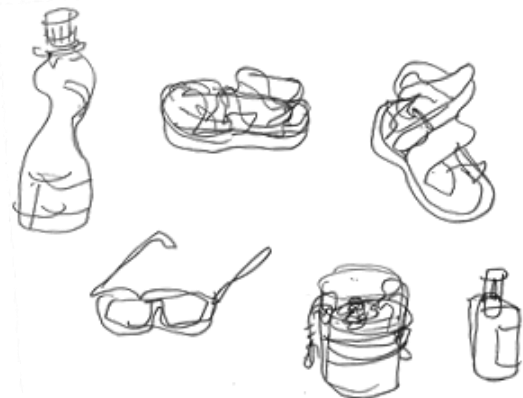
Allied Design Studio is the synchronization of Design Education with all Allied fields of Design.

Through this subject the students are exposed to all Allied Arts thus making their experiences richer and they are equipped with a diverse tool kit for design.

Other than the first two semesters, there is no specified syllabus for Allied Design Studio.

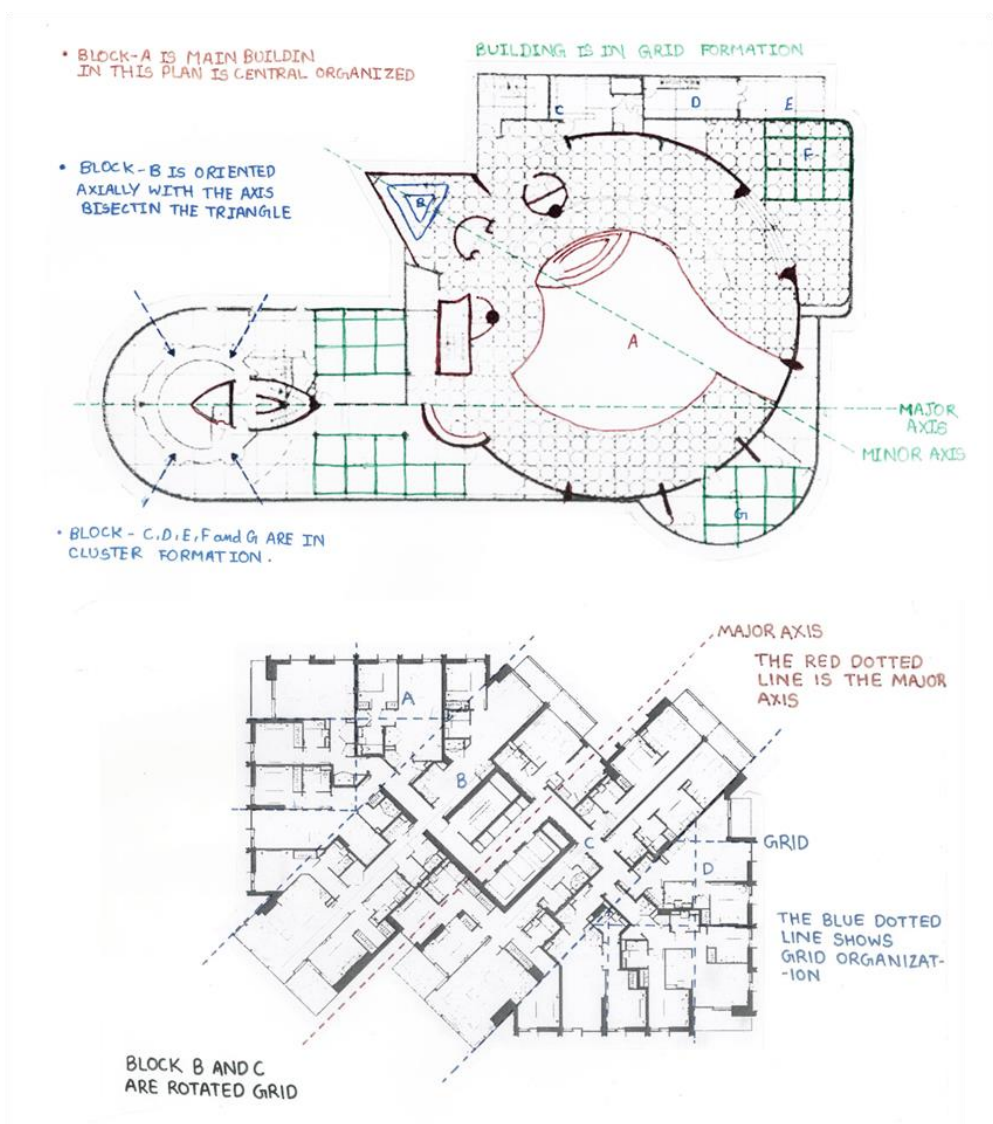
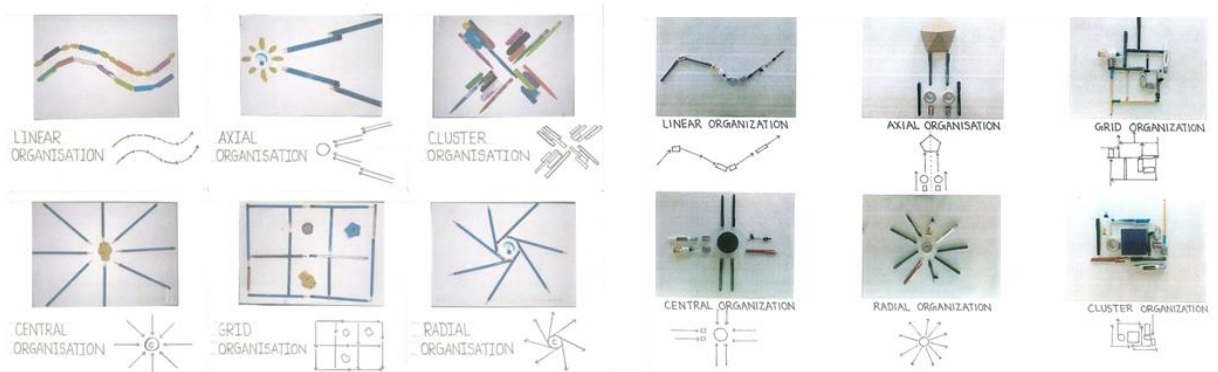
This provides **freedom** for both the students and the faculty to explore various fields of design.





Allied Design Studio

SEMESTER I



Principal
Ideas
Institute of Design Education & Architectural Studies, Nagpur

Allied Design Studio

SEMESTER 2



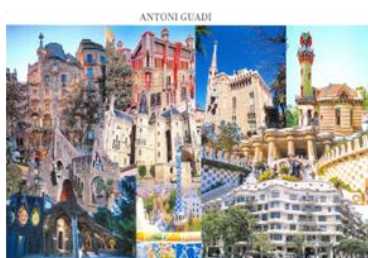
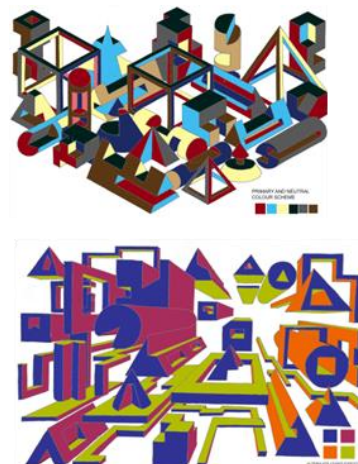
Fig. 1

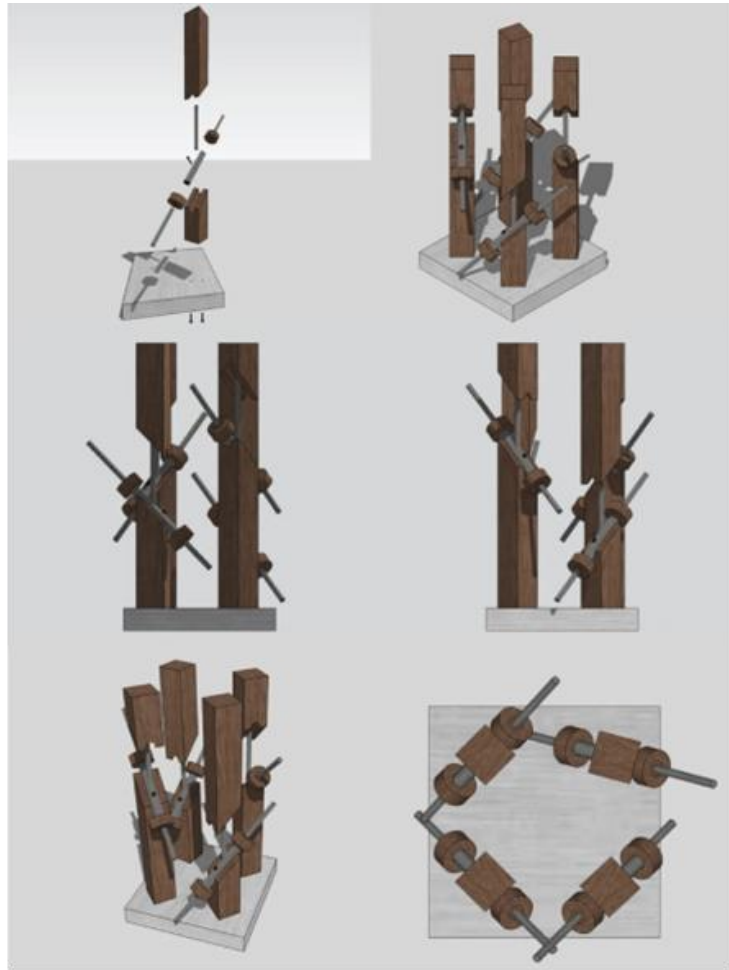
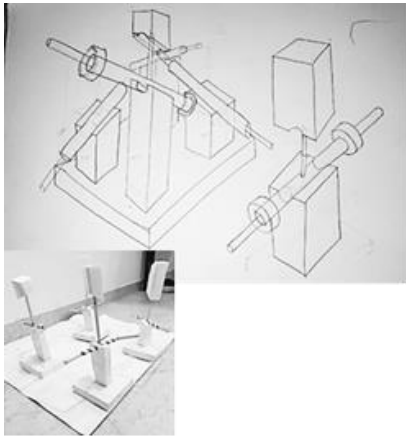


Fig. 3



Fig. 2





Akansha, D, Urja, Z



<p><u>5:30 AM TO 6:30 AM</u></p> <p>• Waking Up • House Cleaning • Cooking</p>	<p><u>7:30 AM TO 8:30 AM</u></p> <p>• Water</p>	<p><u>12:00 PM</u></p> <p>• Eating Food</p>	<p><u>3:00 PM</u></p> <p>• Rest</p>
<p><u>6:00 PM</u></p> <p>• Cooking</p>	<p><u>8:00 PM</u></p> <p>• Eating Food</p>	<p><u>9:30 PM</u></p> <p>• Sleeping</p>	

→ MUD WALL
USE TO CONSTRUCT THEIR HOUSES ON THEIR OWN. WALLS WERE MADE USING MUD.

MADE MANGALORE TILES ON THEIR OWN FOR THE ROOF.

USED TO GRIND GRAINS IN HAND MILL (JAP).

THE TEMPLE WAS THE GATHERING SPACE.

- THE MONSOON SEASON STARTS OFF IN MONTH OF JUNE AND STAYS TILL SEPTEMBER PROVIDING AVERAGE RAINFALL OF 14.48 CM - 12.02 CM.
- THE WIND IN RAMJAM DURING MAY BLOWS AT AN AVERAGE SPEED OF 12.8 km/h (20 km/h). THE WINDIEST MONTH IS JULY WITH AN AVERAGE WIND SPEED OF 23.7 km/h (22.0 km/h). THE CALMEST MONTH IS NOVEMBER WITH AN AVERAGE WIND SPEED OF 8.1 km/h (25.1 mph).
- ALTITUDE - 532 METERS ABOVE SEA LEVEL. TOTAL GEOGRAPHICAL AREA OF THE VILLAGE IS 58.5 HECTARES.

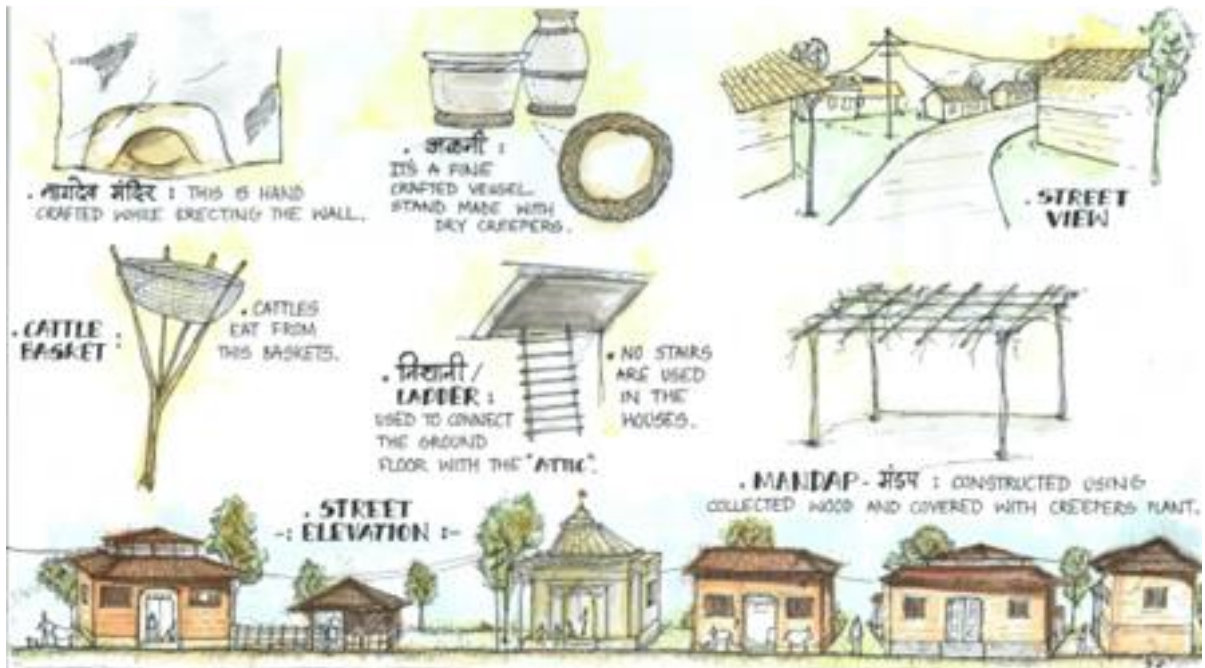
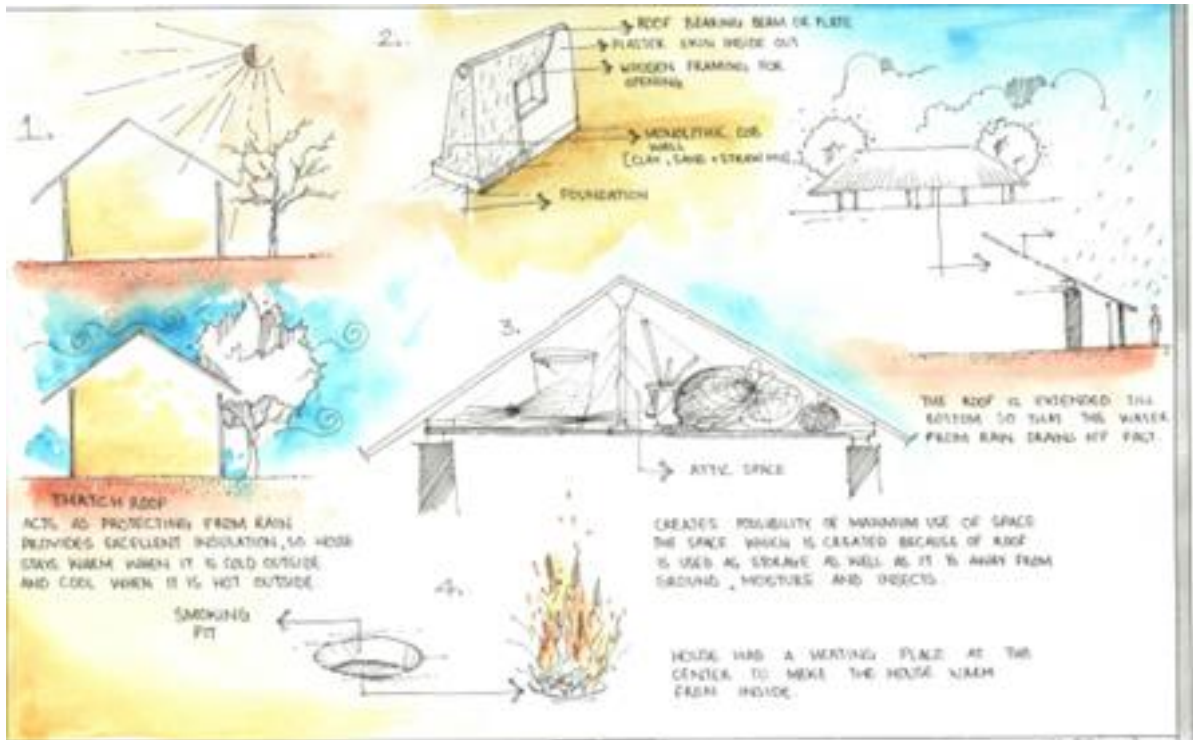
INSTITUTE OF DESIGN EDUCATION AND ARCHITECTURAL STUDIES		
SEMESTER: 3	SIGN:	
REGION:	GRADE:	
GROUP MEMBER: 1) SPANET SANKAR	2) SHAFIQ WAJID	3) ANJUL POORJ
4) VEER SHARDE	5) SHELLE SHARDE	6) YODHIT KUMAR

PEOPLE/
CLIMATE

Principal
Ideas
 Institute of Design Education &
 Architectural Studies, Nagpur

Allied Design Studio

SEMESTER 3



INSTITUTE OF DESIGN EDUCATION AND ARCHITECTURAL STUDIES		
SEMESTER: 5 TH SEM	SIGN	
REGION: CHOTI	GRADE	
GROUP MEMBER	1) MONIKA BHARGAVA	2) ANSHYANT SUTHAR
	3) ANUSOMNKAWAR	4) NISHANT K.
	5) CHETAN RAUT	6) NISHANESH. K.

ART & ARTIFACTS

Principal
Ideas
 Institute of Design Education &
 Architectural Studies, Nagpur

Allied Design Studio

SEMESTER 3